

1. Determine the acceleration and the tensions

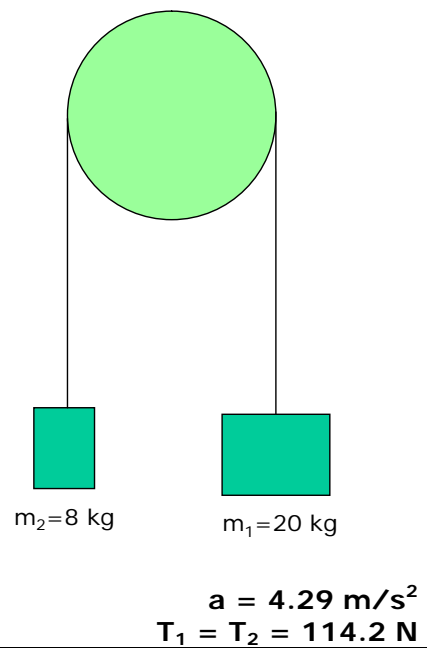

① → Whole system:

$$F_{\text{net}} = W_1 - T_1 + T_2 - W_2 = W_1 - W_2 =$$

$$= 200 \text{ N} - 80 \text{ N} = 120 \text{ N}$$

$$F_{\text{net}} = m \times a \rightarrow 120 \text{ N} = 28 \text{ Kg} \times a \rightarrow a = 4.29 \frac{\text{m}}{\text{s}^2}$$

→ An isolated body:



$$F_{\text{net}} = m \times a$$

$$200 \text{ N} - T_1 = 20 \text{ Kg} \times 4.29 \frac{\text{m}}{\text{s}^2} = 85.8 \text{ N}$$

$$T_1 = T_2 = 114.2 \text{ N}$$

2. Determine the acceleration of the system and the value of the tensions. The coefficient of friction is $\mu=0,2$

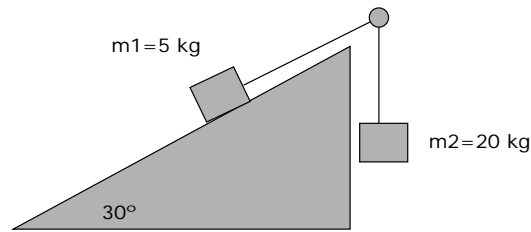

$$a = 6.65 \text{ m/s}^2$$

$$T_1 = T_2 = 67 \text{ N}$$

② → Determination of W_{1x} , W_{1y} , N and F_f

$$W_{1x} = W_1 \cdot \sin 30^\circ = 25 \text{ N}$$

$$W_{1y} = W_1 \cdot \cos 30^\circ = 43.3 \text{ N}$$

$$N = W_{1y} = 43.3 \text{ N}$$

$$F_f = \mu \times N = 0.2 \times 43.3 \text{ N} = 8.7 \text{ N}$$

→ Application to the whole system:

$$F_{\text{net}} = W_2 - T_2 + T_1 - F_f - W_{1x} =$$

$$= 200 \text{ N} - 8.7 \text{ N} - 25 \text{ N} = 166.3 \text{ N}$$

$$F_{\text{net}} = m \times a \rightarrow 166.3 \text{ N} = 25 \text{ Kg} \times a \rightarrow a = 6.65 \frac{\text{m}}{\text{s}^2}$$

→ Application to an isolated body:



$$F_{\text{net}} = m \times a$$

$$200 \text{ N} - T_2 = 20 \text{ Kg} \times 6.65 \frac{\text{m}}{\text{s}^2} = 133 \text{ N}$$

$$T_1 = T_2 = 67 \text{ N}$$

3. Determine the acceleration and the tensions. The coefficient of friction is 0.5.

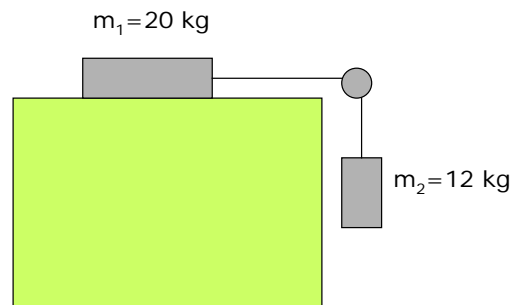

$$a = 0.625 \text{ m/s}^2$$

$$T_1 = T_2 = 112.5 \text{ N}$$

③ → Determination of N and F_f

$$N = W_1 = 200 \text{ N}$$

$$F_f = \mu \times N = 0.5 \times 200 \text{ N} = 100 \text{ N}$$

→ Application to the whole system

$$F_{\text{net}} = W_2 - T_2 + T_1 - F_f =$$

$$= 120 \text{ N} - 100 \text{ N} = 20 \text{ N} \rightarrow a = 0.625 \frac{\text{m}}{\text{s}^2}$$

→ Application to an isolated body

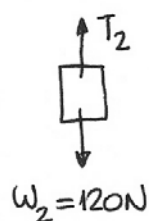

$$F_{\text{net}} = m \times a$$

$$120 \text{ N} - T_2 = 12 \text{ kg} \times 0.625 \frac{\text{m}}{\text{s}^2} = 7.5 \text{ N}$$

$$T_1 = T_2 = 112.5 \text{ N}$$

4. Calculate the acceleration of the system and the tensions

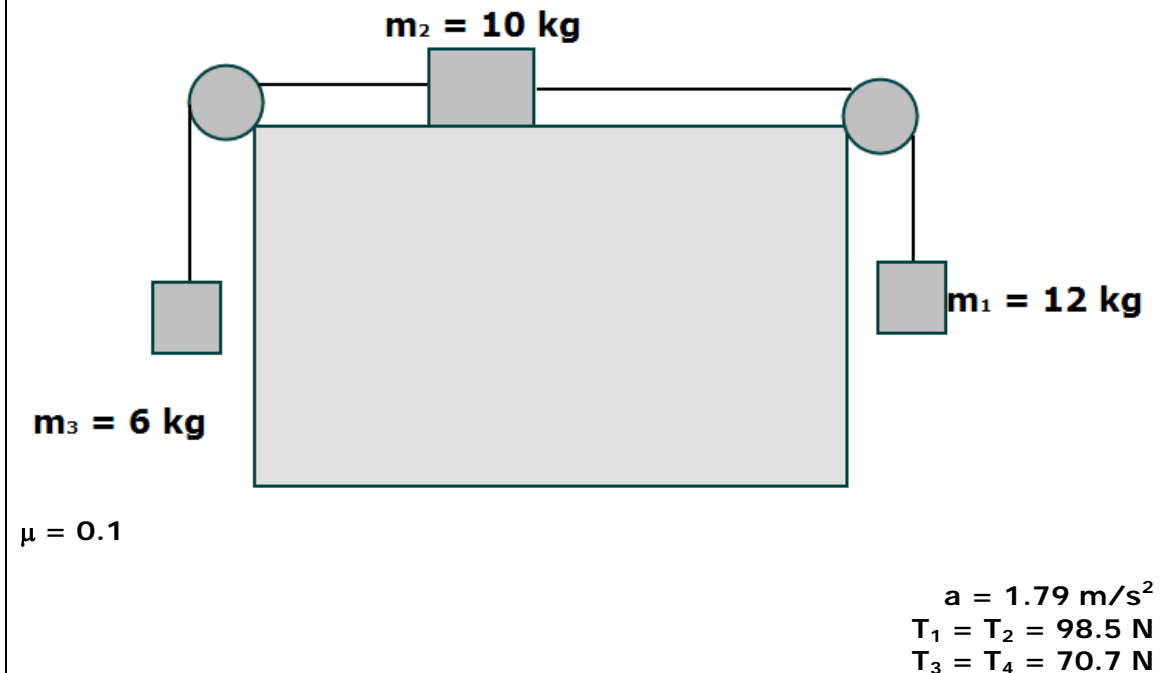

④ → Determination of N and F_f

$$N = W_2 = 100 \text{ N}$$

$$F_f = \mu \times N = 0.1 \times 100 \text{ N} = 10 \text{ N}$$

→ Application to the whole system

$$F_{\text{net}} = W_1 - T_1 + T_2 - T_3 + T_4 - W_3 = F_f =$$

$$= 120 \text{ N} - 60 \text{ N} - 10 \text{ N} = 50 \text{ N}$$

$$F_{\text{net}} = m \times a \rightarrow 50 \text{ N} = 28 \text{ kg} \times a \rightarrow a = 1.79 \text{ m/s}^2$$

→ Application to isolated bodies:

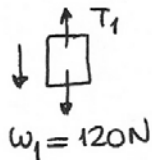

$$120 \text{ N} - T_1 = 12 \text{ kg} \times 1.79 \text{ m/s}^2 = 21.5 \text{ N}$$

$$T_1 = T_2 = 98.5 \text{ N}$$

$$T_4 - 60 \text{ N} = 6 \text{ kg} \times 1.79 \frac{\text{m}}{\text{s}^2} = 10.7 \text{ N}$$

$$T_3 = T_4 = 70.7 \text{ N}$$

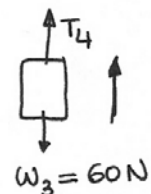

5. Calculate the acceleration and the tensions

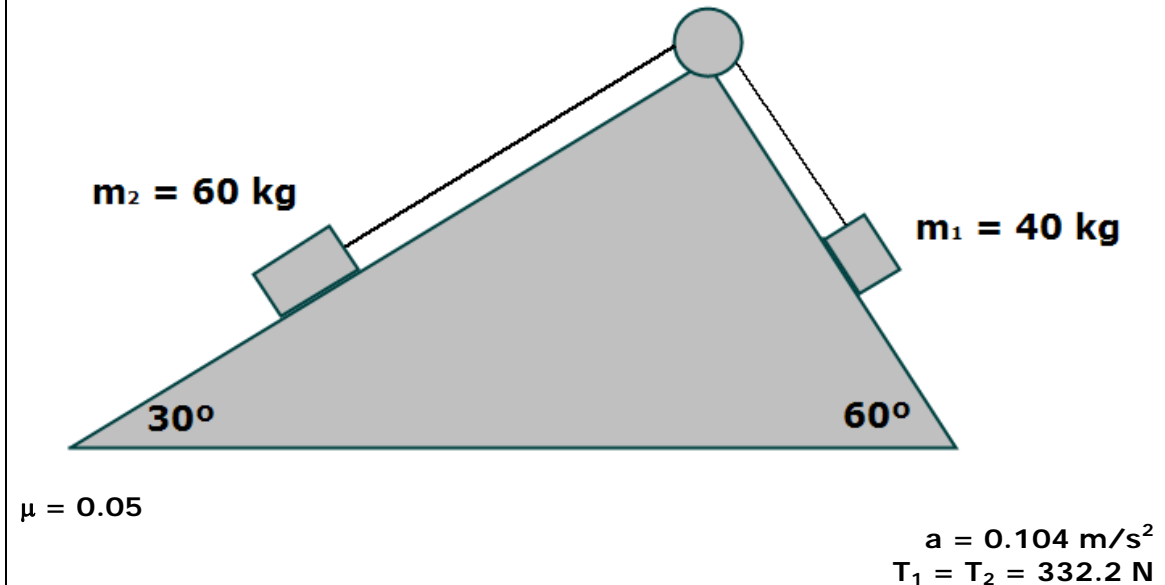

⑤ → Determination of forces and the direction of motion

$$W_{1x} = W_1 \times \sin 60^\circ = 346.4 \text{ N}$$

$$W_{1y} = W_1 \times \cos 60^\circ = 200 \text{ N}$$

$$W_{2x} = W_2 \times \sin 30^\circ = 300 \text{ N}$$

$$W_{2y} = W_2 \times \cos 30^\circ = 519.6 \text{ N}$$

$W_{1x} > W_{2x}$ → direction of motion:

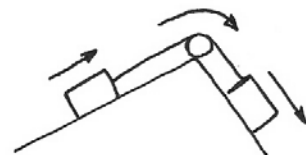

$$N_1 = W_{1y} = 200 \text{ N}$$

$$F_{f1} = \mu \times N_1 = 0.05 \times 200 \text{ N} = 10 \text{ N}$$

$$N_2 = W_{2y} = 519.6 \text{ N}$$

$$F_{f2} = \mu \times N_2 = 26 \text{ N}$$

↳ Application to the whole system

$$F_{net} = W_{1x} - T_1 + T_2 - F_{f1} - W_{2x} - F_{f2} = \\ = 346.4 \text{ N} - 10 \text{ N} - 300 \text{ N} - 26 \text{ N} = 10.4 \text{ N}$$

$$F_{net} = m \times a \rightarrow 10.4 \text{ N} = 100 \text{ Kg} \times a \rightarrow a = 0.104 \text{ m/s}^2$$

↳ Application to an isolated body

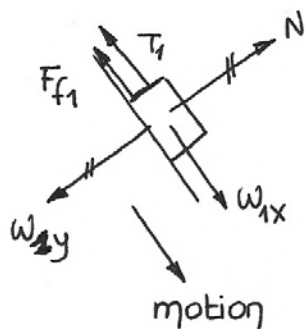

$$F_{net} = m \times a$$



$$346.4 \text{ N} - 10 \text{ N} - T_1 = 40 \text{ Kg} \times 0.104 \text{ m/s}^2 = \\ = 4.2 \text{ N}$$

$$T_1 = T_2 = 346.4 \text{ N} - 10 \text{ N} - 4.2 \text{ N} = \\ = 332.2 \text{ N}$$