

**Exam: CHEMICAL CALCULUS**  
**1. Batxilergoa**

Name:

Group:

**1** The concentration of a NaCl solution is 2M and the density is 1.10 g/mL. Calculate the concentration in

- g/L
- weight percentage

Atomic weights: Na=23; Cl=35.5

STRATEGY

We have to convert the units of the concentration:

concentration  $\xrightarrow{\text{Molar mass}}$  concentration  $\xrightarrow{\text{Density}}$  concentration  
M  $\xrightarrow{\hspace{2cm}}$  g/L  $\xrightarrow{\hspace{2cm}}$  %

SOLUTION

Molar mass:  $M = 23 + 35.5 = 58.5 \frac{\text{g NaCl}}{\text{mol NaCl}}$

concentration (g/L) =  $2 \frac{\text{mol NaCl}}{\text{L sol}} \cdot \frac{58.5 \text{ g NaCl}}{1 \text{ mol NaCl}} = 117 \frac{\text{g NaCl}}{\text{L sol}}$

concentration (%) =  $117 \frac{\text{g NaCl}}{\text{L sol}} \cdot \frac{1 \text{ L sol}}{1000 \text{ mL sol}} \cdot \frac{1 \text{ mL sol}}{1.10 \text{ g sol}} \cdot 100 = 10.64\%$

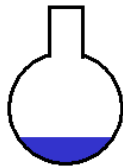



|                   |   |  |     |  |
|-------------------|---|--|-----|--|
| <b>soluto</b>     | m =   | <input style="width: 80%;" type="text"/> | g   | <div style="border: 1px solid black; padding: 2px; display: inline-block;">M=58.5</div>  |
|                   | n =   | <input style="width: 80%;" type="text"/> | mol |  |
| <b>disolución</b> | V =   | <input style="width: 80%;" type="text"/> | L   |  |
|                   | <div style="border: 1px solid black; padding: 5px; display: inline-block; background-color: #e0e0ff;"> <math>m, n = c \cdot V</math> </div> |  |     |  |
|                   | c =   | <input style="width: 80%;" type="text"/> | g/L | <div style="border: 1px solid black; padding: 2px; display: inline-block;">M=58.5</div> <div style="border: 1px solid black; padding: 2px; display: inline-block; margin-left: 20px;">d=1.1 g/mL</div> |
|                   | c =   | <b>2</b>                                 | M   |  |
| c =               | <input style="width: 80%;" type="text"/>  | ‰  |     |  |

2 A container has a solution of nitric acid and from that container we can read the following information:

- $\text{HNO}_3$
- 40 %
- $d=1.25 \text{ g/mL}$

Calculate the volume we need to take from this container in order to get 500 mL of a solution 0.3 M by dilution.

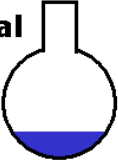
Atomic weights: N=14; H=1; O=16

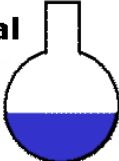
|                 |     |   |     |  |   |   |
|-----------------|-----|---|-----|--|---|---|
|                 |     | <b>initial</b>  |     | <b>added</b>   |   | <b>final</b>  |
|                 |     |  |     |  |   |  |
| <b>solute</b>   | m = | <input type="text"/>  | g   | <input type="text" value="0"/>   | = | <input type="text"/>  |
|                 | n = | <input type="text"/>  | mol | <input type="text" value="0"/>   | = | <input type="text"/>  |
| <b>solution</b> | V = | <input type="text"/>  | L   | <input type="text"/>   | = | <input type="text" value="0.5"/>  |
|                 |     | $m, n = c \cdot V$  |     |  |   |   |
|                 | c = | <input type="text"/>  | g/L | <input type="text"/>   |   | <input type="text"/>  |
|                 | c = | <input type="text"/>  | M   | <input type="text"/>   |   | <input type="text" value="0.3"/>  |
|                 | c = | <input type="text" value="40"/>   | %   | <input type="text"/>   |   | <input type="text"/>  |

### STRATEGY

1. calculate the number of moles of solute in the final solution
2. calculate the number of moles of the initial solution
3. calculate the concentration of the initial solution in mol/L
4. calculate the volume of the initial solution

$$n_3 = 0.3 \frac{\text{mol HNO}_3}{\text{L sol}} \cdot 0.5 \text{ L sol} = 0.15 \text{ mol HNO}_3$$

$$n_1 = n_3 = 0.15 \text{ mol HNO}_3$$

$$c_1 \text{ (M)} = \frac{40 \text{ g HNO}_3}{100 \text{ g sol}} \cdot \frac{1250 \text{ g sol}}{1 \text{ L sol}} \cdot \frac{1 \text{ mol HNO}_3}{63 \text{ g HNO}_3} = 7.94 \text{ M}$$

$$V_1 = 0.15 \text{ mol HNO}_3 \cdot \frac{1 \text{ L sol}}{7.94 \text{ mol}} = 0.019 \text{ L} = 19 \text{ mL}$$

**3** When we burn butane (C<sub>4</sub>H<sub>10</sub>) carbon dioxide and water are formed. Calculate the amount of butane we need to burn in order to get 18 L of carbon dioxide in the following conditions: temperature=27°C and pressure=2 atm.

Atomic weights: C=12; H=1; O=16

$$R = 0.082 \frac{\text{atm.L}}{\text{K.mol}}$$

The adjusted equation

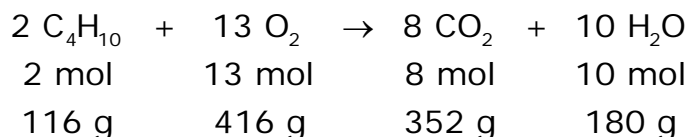

$$M(\text{C}_4\text{H}_{10}) = (4 \times 12) + (10 \times 1) = 58 \text{ g/mol}$$

$$M(\text{O}_2) = 2 \times 16 = 32 \text{ g/mol}$$

$$M(\text{CO}_2) = 12 + (2 \times 16) = 44 \text{ g/mol}$$

$$M(\text{H}_2\text{O}) = (2 \times 1) + 16 = 18 \text{ g/mol}$$

The amount of carbon dioxide that is contained in 18 L:

$$p.V = n.R.T \rightarrow n = \frac{p.V}{R.T} = \frac{2 \text{ atm} \times 18 \text{ L}}{0.082 \frac{\text{atm L}}{\text{K mol}} \times (273+27) \text{ K}} = 1.46 \text{ mol CO}_2$$

In order to get those 1.46 mol of carbon dioxide we need:

$$m(\text{C}_4\text{H}_{10}) = 1.46 \text{ mol CO}_2 \cdot \frac{116 \text{ g C}_4\text{H}_{10}}{8 \text{ mol CO}_2} = 21.17 \text{ g C}_4\text{H}_{10}$$

**4** When zinc metal and hydrochloric acid combine with each other, zinc chloride ( $\text{ZnCl}_2$ ) and hydrogen are formed.

If we put together 20 g of a sample of zinc (85 % of purity) and 250 mL of a solution of HCl 3M,

- determine the limiting reactant
- calculate the amount of zinc chloride formed
- calculate the volume of hydrogen at STP
- calculate the excess of reactant

Atomic weights:  $\text{Zn}=65.4$ ;  $\text{Cl}=35.5$   $\text{H}=1$

The amount of reactants added are:

$$m(\text{Zn}) = 20 \text{ g sample} \times \frac{85 \text{ g Zn}}{100 \text{ g sample}} = 17 \text{ g Zn}$$

$$n(\text{HCl}) = 250 \text{ mL sol} \cdot \frac{3 \text{ mol HCl}}{1000 \text{ mL sol}} = 0.75 \text{ mol HCl}$$

The balanced chemical equation and the limiting reactant are:

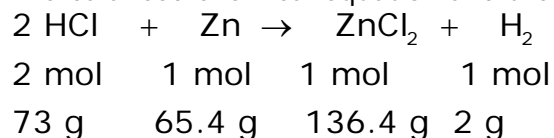

$$\text{HCl} \dots \frac{0.75 \text{ mol}}{2 \text{ mol}} = 0.375 \text{ times the value of the table}$$

$$\text{Zn} \dots \frac{17 \text{ g}}{65.4 \text{ g}} = 0.26 \text{ times the value of the table}$$

Zn is the limiting reactant

The amount of zinc chloride formed is:

$$m(\text{ZnCl}_2) = 17 \text{ g Zn} \cdot \frac{136.4 \text{ g ZnCl}_2}{65.4 \text{ g Zn}} = 35.46 \text{ g ZnCl}_2$$

The volume of hydrogen at STP:

$$V(\text{H}_2) = 17 \text{ g Zn} \cdot \frac{1 \text{ mol H}_2}{65.4 \text{ g Zn}} \cdot \frac{22.4 \text{ L}}{1 \text{ mol}} = 5.82 \text{ L H}_2$$

The excess of reactant:

- the amount of HCl consumed:

$$n(\text{HCl}) = 17 \text{ g Zn} \cdot \frac{2 \text{ mol HCl}}{65.4 \text{ g Zn}} = 0.52 \text{ mol HCl}$$

- the excess of HCl:

$$n(\text{HCl}) = 0.75 \text{ mol HCl} - 0.52 \text{ mol HCl} = 0.23 \text{ mol HCl}$$