

Born-Haber Cycle

The Born-Haber cycle

The energies involved in the formation of an ionic compound can be classified as:

- Energies involved in the formation of isolated atoms
- Energies involved in the formation of isolated ions
- Energy involved in the formation of an ionic solid.

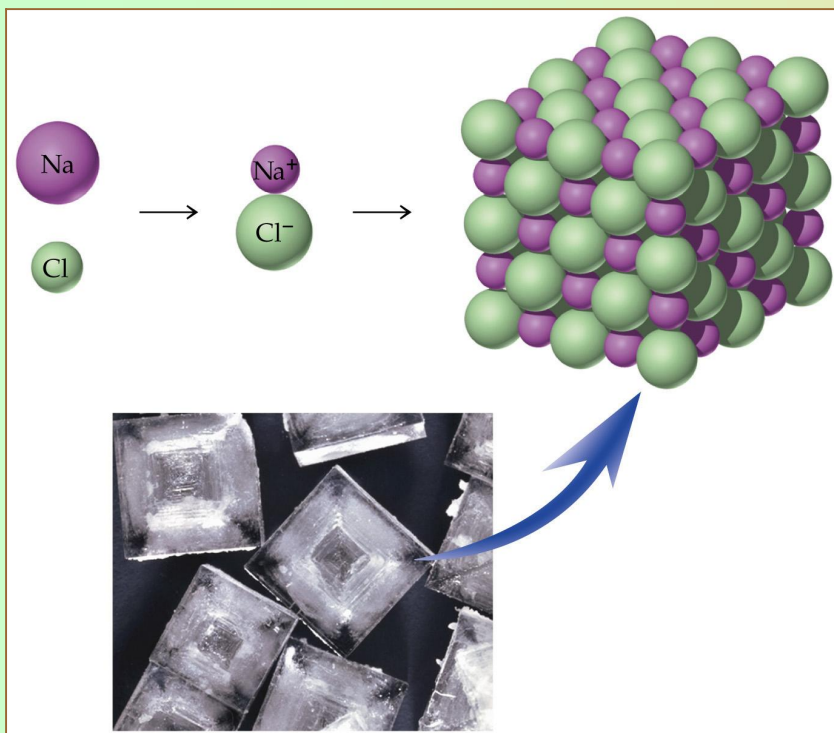

http://wps.prenhall.com/wps/media/objects/602/616516/Media_Assets/Chapter06/Text_Images/FG06_07.JPG

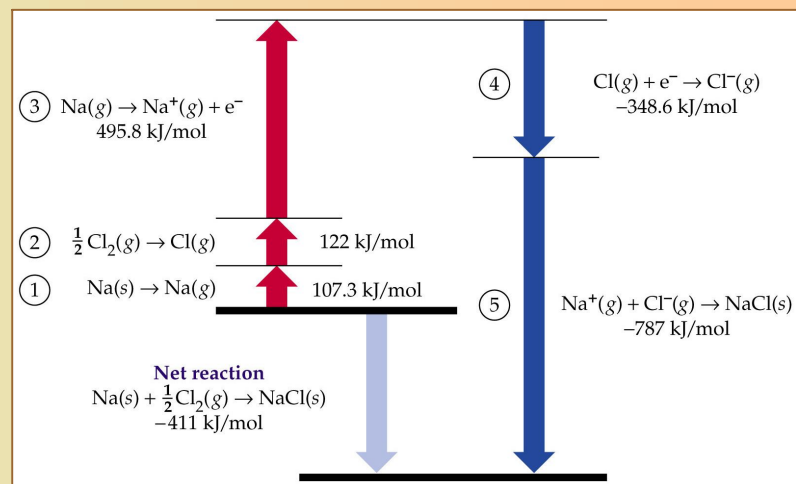

Born-Haber Cycle

Steps involved in the formation of an ionic compound (NaCl)

FORMATION OF ISOLATED ATOMS

1. Vaporization (atomization) enthalpy of sodium ... (V)
2. Dissociation enthalpy of chlorine ... (D/2)

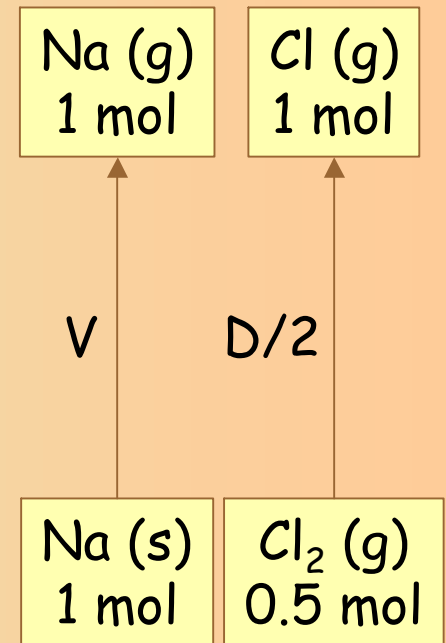
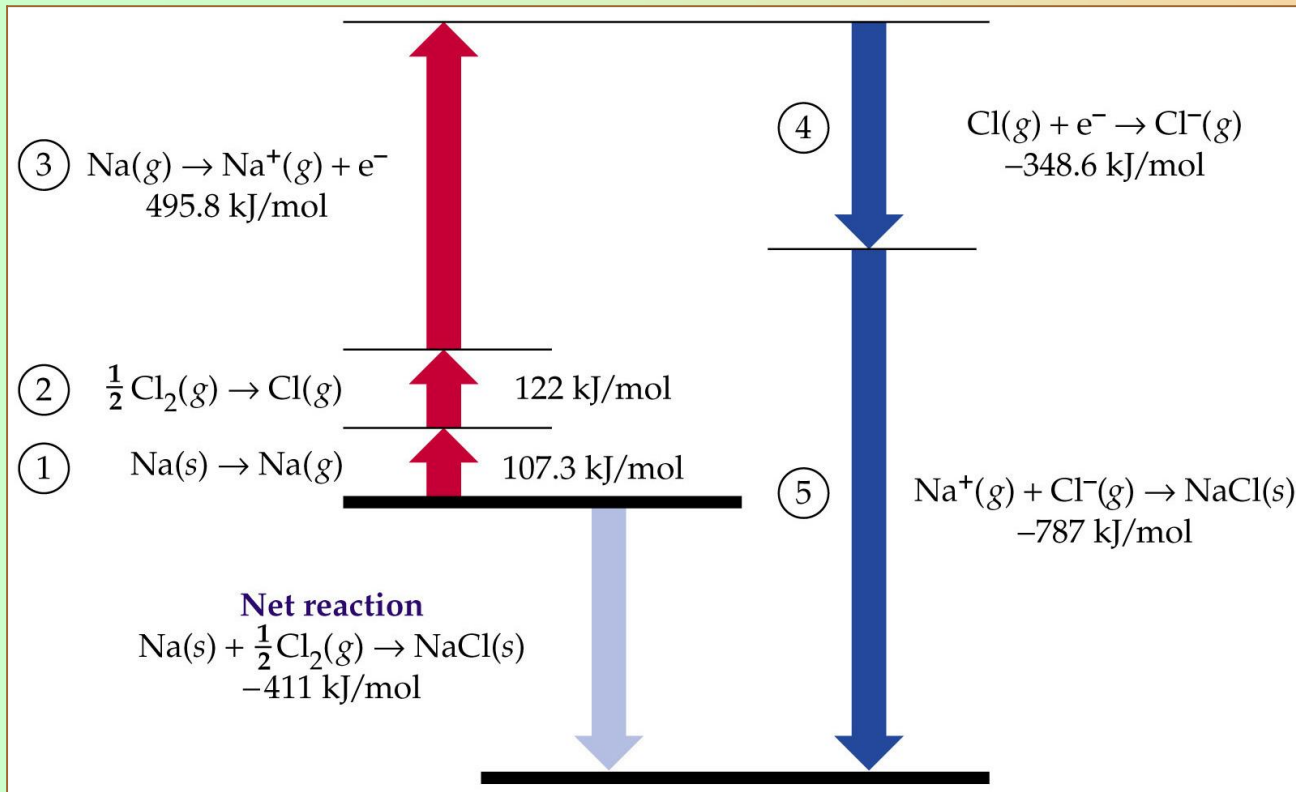

Born-Haber Cycle

Steps involved in the formation of an ionic compound (NaCl)

FORMATION OF ISOLATED IONS

3. Ionization enthalpy of sodium (IE)
4. Electron affinity of chlorine (EA)

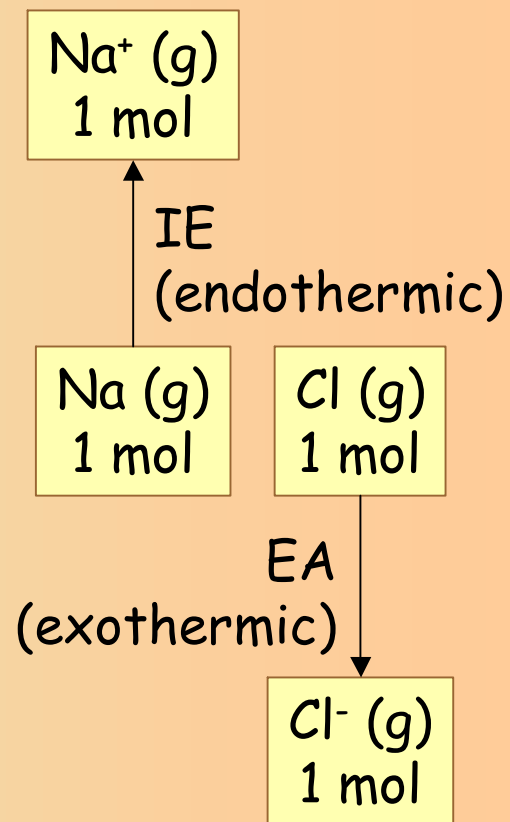
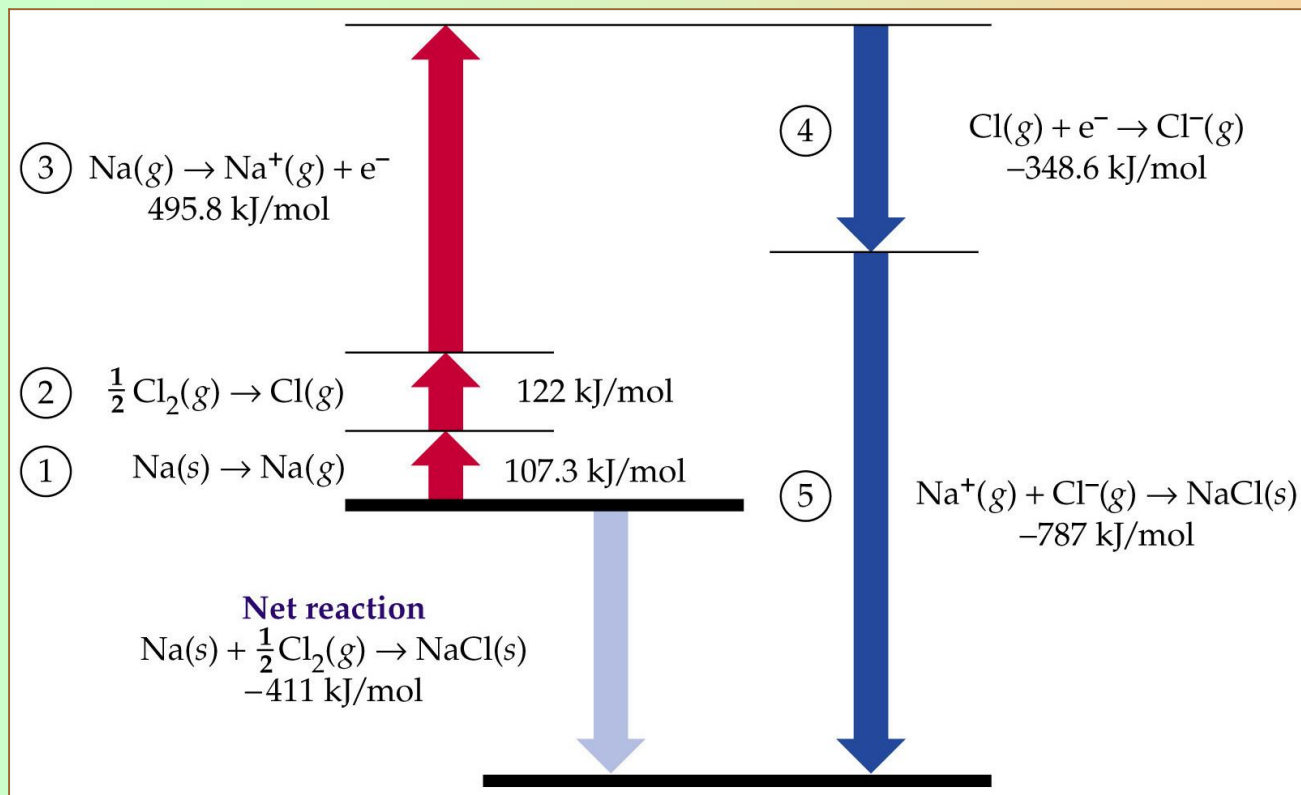

Born-Haber Cycle

Steps involved in the formation of an ionic compound (NaCl)

FORMATION OF THE IONIC SOLID

5. Lattice enthalpy (L)

The enthalpy of formation of sodium chloride:

$$\Delta H_f^0 = \underbrace{V + \frac{1}{2} D + IE}_{\text{endothermic}} + \underbrace{EA + L}_{\text{exothermic}}$$

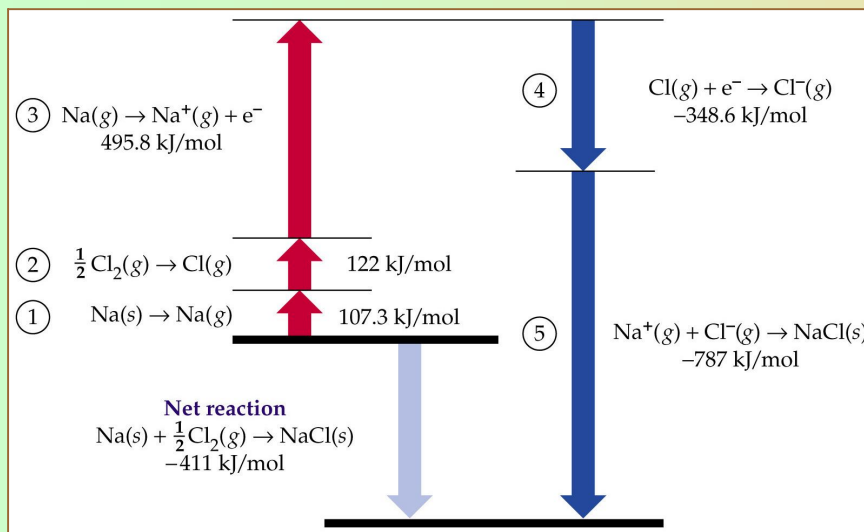
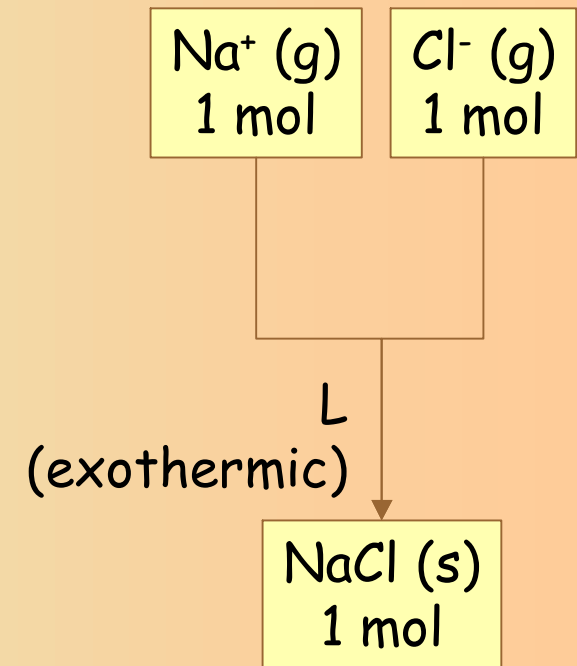

Born-Haber Cycle

Lattice Enthalpy

The lattice enthalpy (energy) of an ionic solid is a measure of the strength of bonds in that ionic compound.

