

# Spontaneity

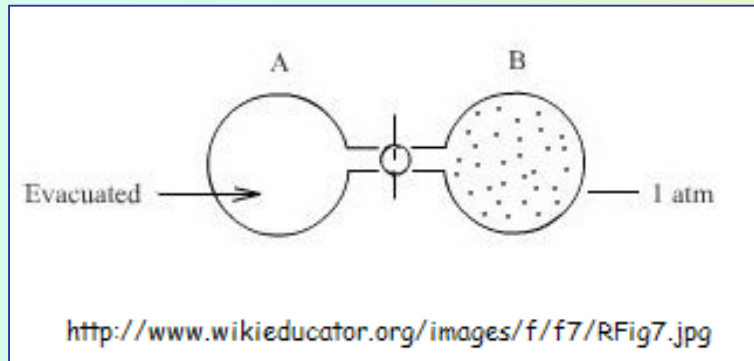

Let's study some spontaneous processes.

## The Spontaneous Expansion of a Gas

Imagine an ideal gas confined to a flask.

The gas will spontaneously expand to the second flask.

The reverse process (in which a evenly distributed gas moves entirely to one of the flasks) is very improbable.

Therefore, one process is spontaneous and the reverse process is highly improbable: there is one preferred direction is this process of expansion.

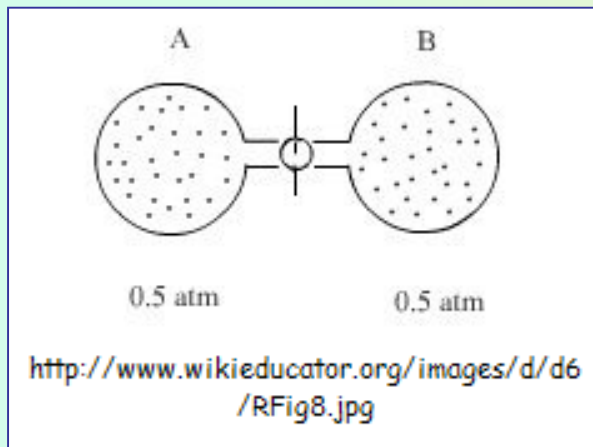

# Spontaneity

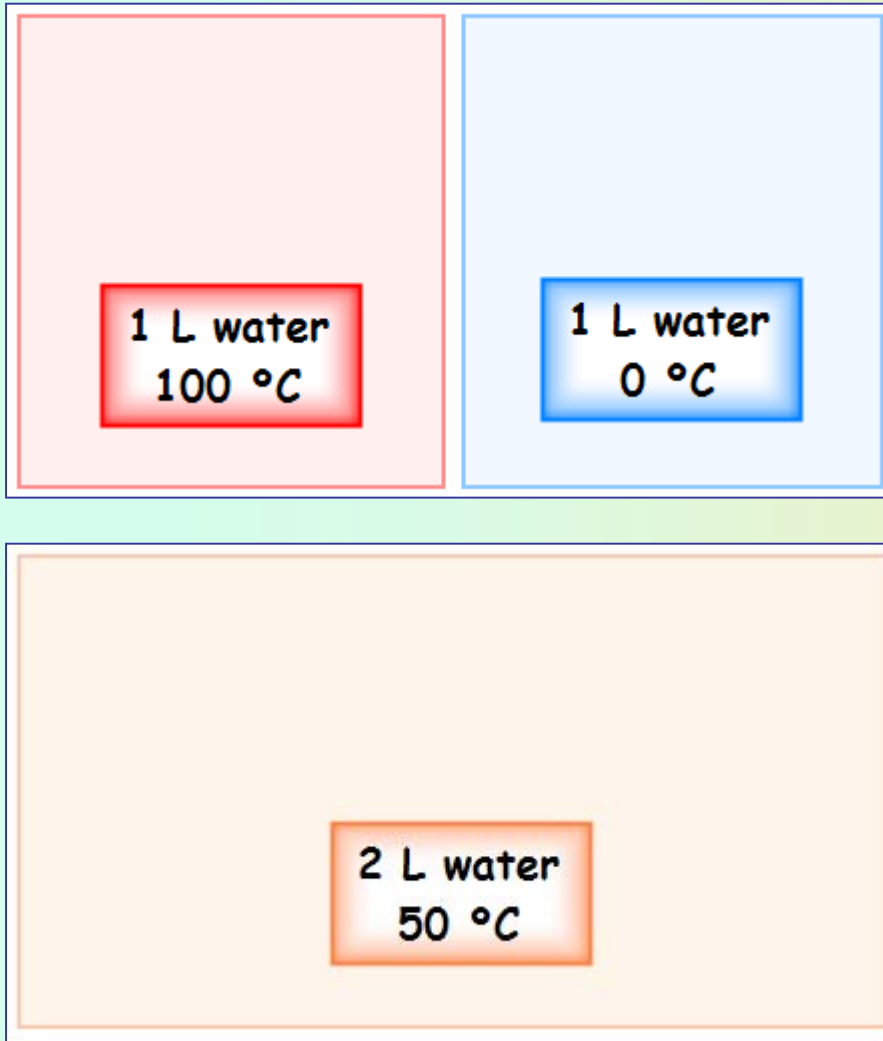

## The mixing of water at different temperatures

Let's suppose that we have those two pictures.

In the first picture we have 2 L of water at 50 °C.

In the second picture we have 1 L of water at 0°C and 1 L of water at 100 °C.

Both are part of the same process.

We know easily which one is the initial state and which the final state, because one direction of the process is highly probable and the reverse is not.

# Spontaneity



## The melting of ice

The endothermic-exothermic factor is not enough to know if a process or a reaction is spontaneous or not.

For instance, ice at 25 °C melts spontaneously, even if the process is endothermic: the ice absorbs energy in order to melt.

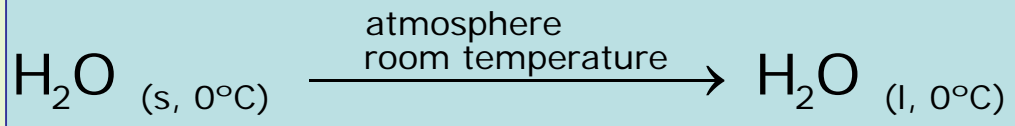

# Spontaneity

## The dissolution of an ionic crystal

When an NaCl crystal is in contact with water, it dissolves into water at certain extent, spontaneously.

In NaCl solid, the ions are held rigidly in place in the crystal. The ions are highly ordered in the crystalline structure.

When the NaCl solid dissolves, the ions are free to move about in the water. They are in a much more random and disordered state than before.

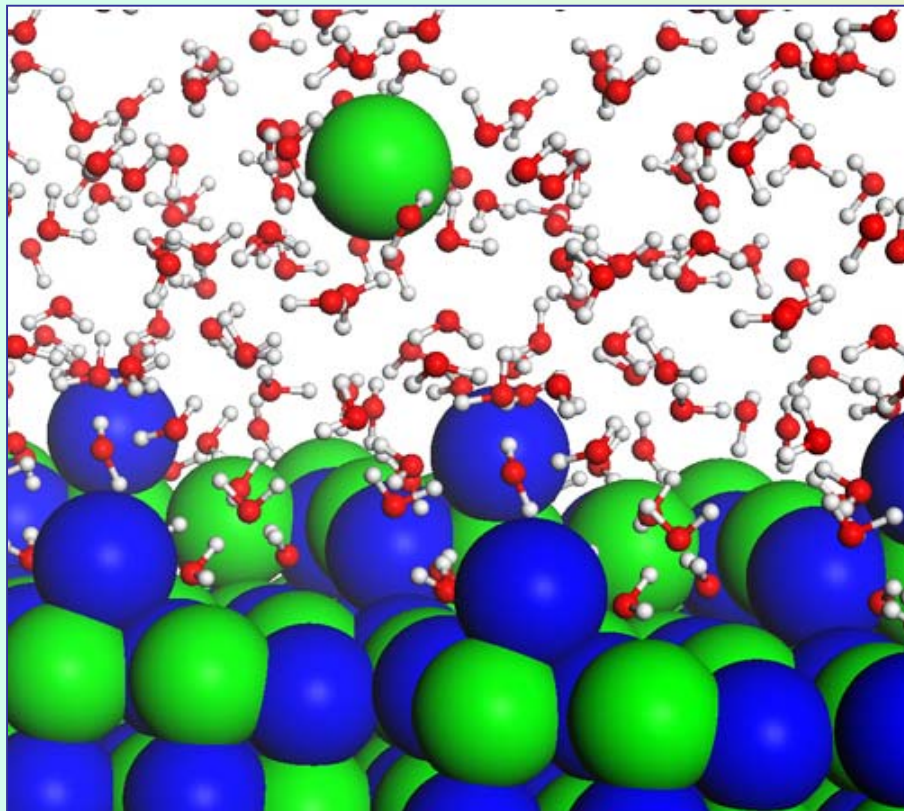

<http://www.ucl.ac.uk/news/ucl-views/0803/salt500>

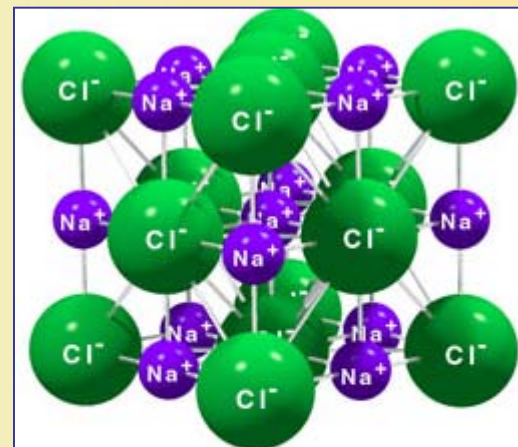

<http://www.chemistry.wustl.edu/~edudev/LabTutorials/Water/PublicWaterSupply/images/nacl.jpg>

# Spontaneity

If the particles represent gas molecules at normal temperatures inside a closed container, which of the illustrated configurations came first?

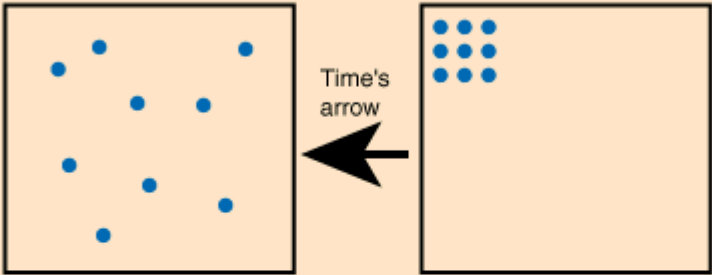

If you tossed bricks off a truck, which kind of pile of bricks would you more likely produce?

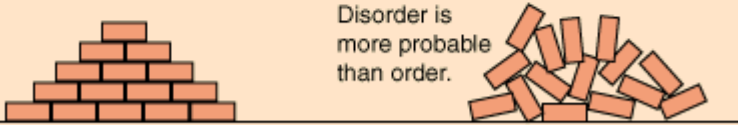

Disorder is more probable than order.

<http://hyperphysics.phy-astr.gsu.edu/hbase/therm/entrop.html>

## Disorder and Entropy

The change in disorder (along with the change in energy) affects the spontaneity of chemical processes.

The disorder is expressed by a thermodynamic quantity called **entropy**, given the symbol  $S$ .

The more disordered or random a system, the larger its entropy.