

Born-Haber Zikloa

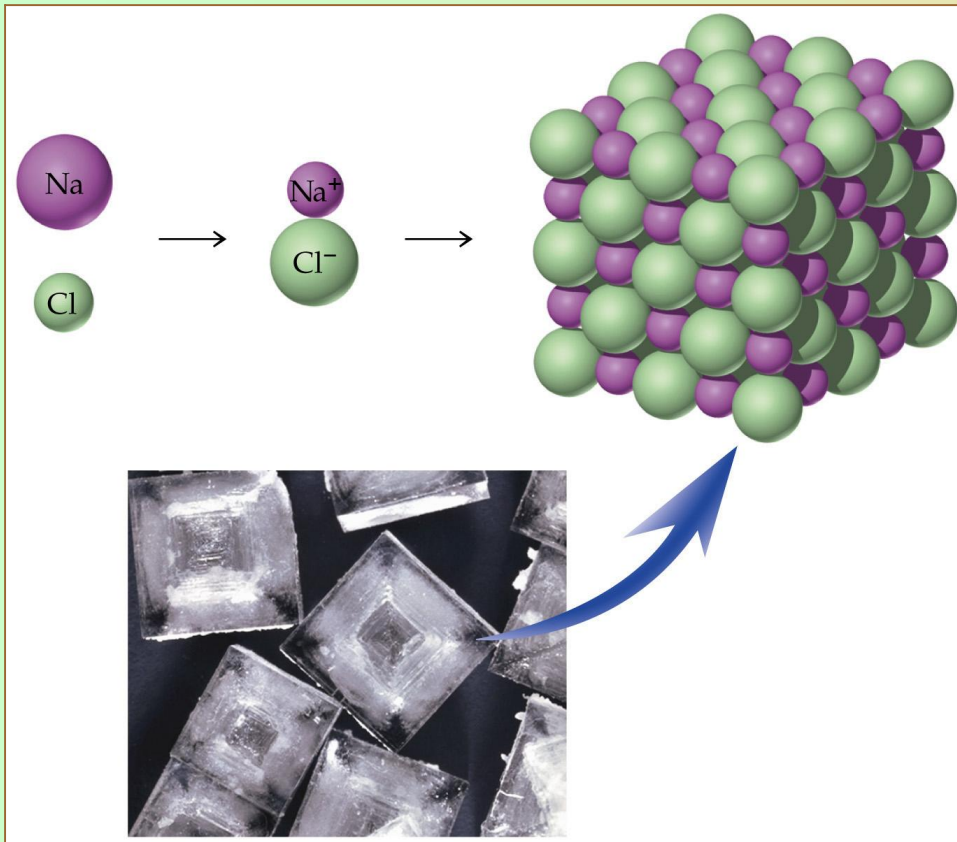

http://wps.prenhall.com/wps/media/objects/602/616516/Media_Assets/Chapter06/Text_Images/FG06_07.JPG

Born-Haber zikloa

Born-Haber zikloa substantzia ionikoaren sorreran jokoan sartzen diren prozesu energetikoen hurbilketa bat da.

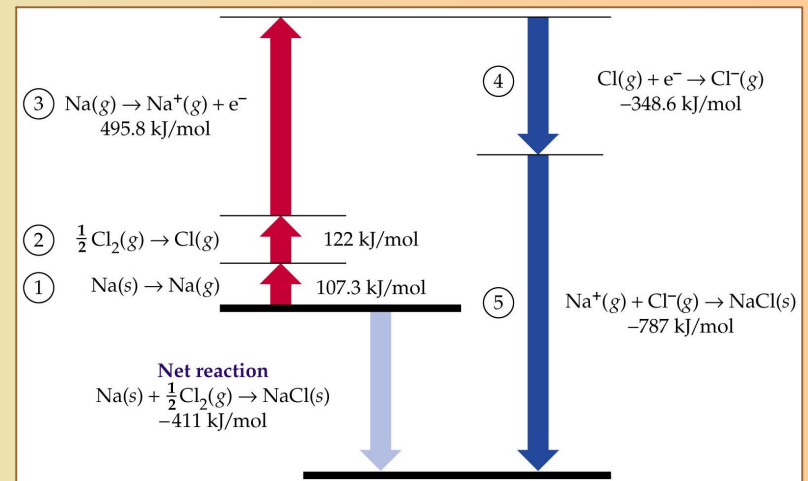

Born-Haber Zikloa

Born-Haber zikloa

Prozesu energetiko hauek honela taldeka daitezke:

- Atomo isolatuen eraketen prozesu energetikoak
- Ioi isolatuen eraketen prozesu energetikoak
- Solido ionikoaren eraketaren prozesu energetikoa.

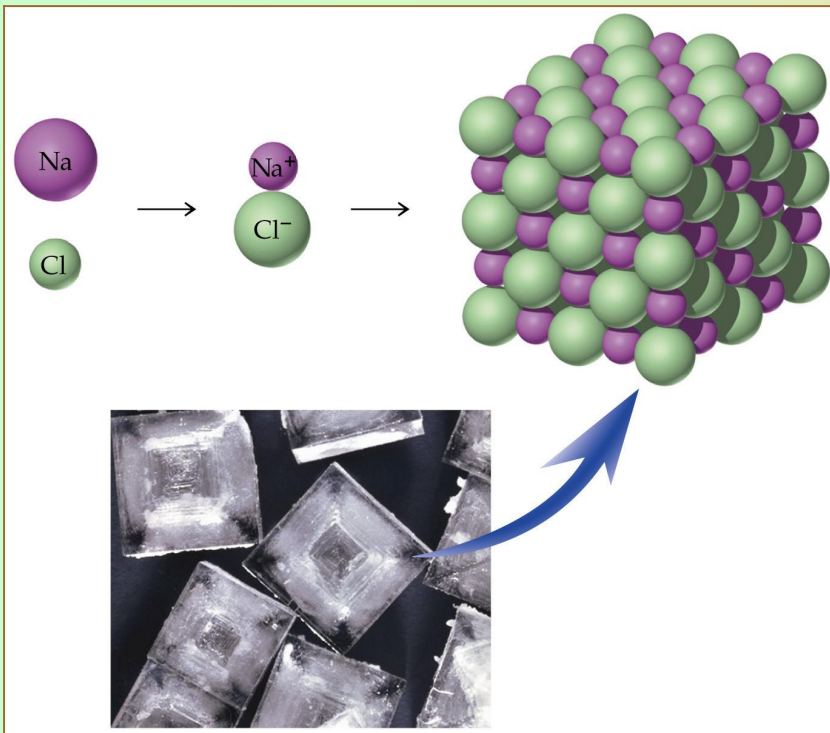

http://wps.prenhall.com/wps/media/objects/602/616516/Media_Assets/Chapter06/Text_Images/FG06_07.JPG

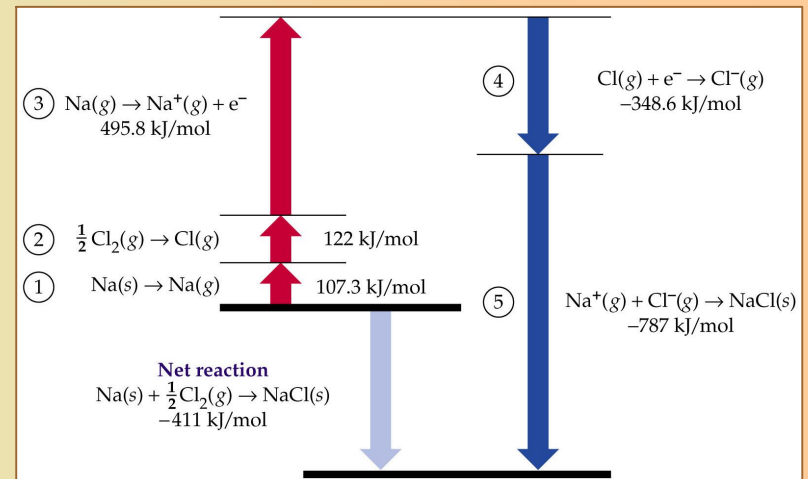

Born-Haber Zikloa

Solido ionikoaen eraketaren urratsak (NaCl)

ATOMO ISOLATUEN ERAKETA

1. Sodioaren lurrinketa (atomizazioa) entalpia... (V)
2. Kloroaren disoziazio-entalpia... (D/2)

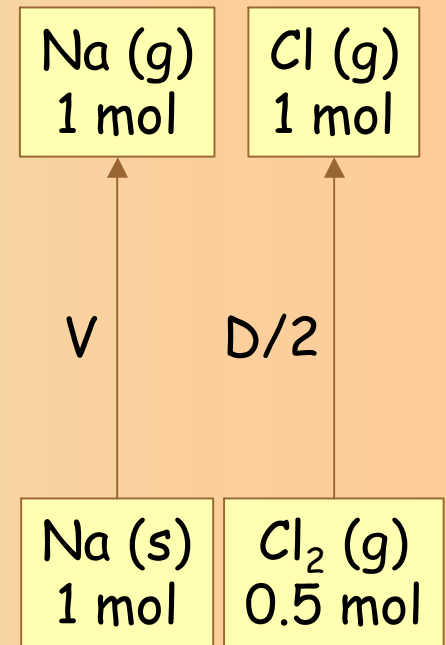
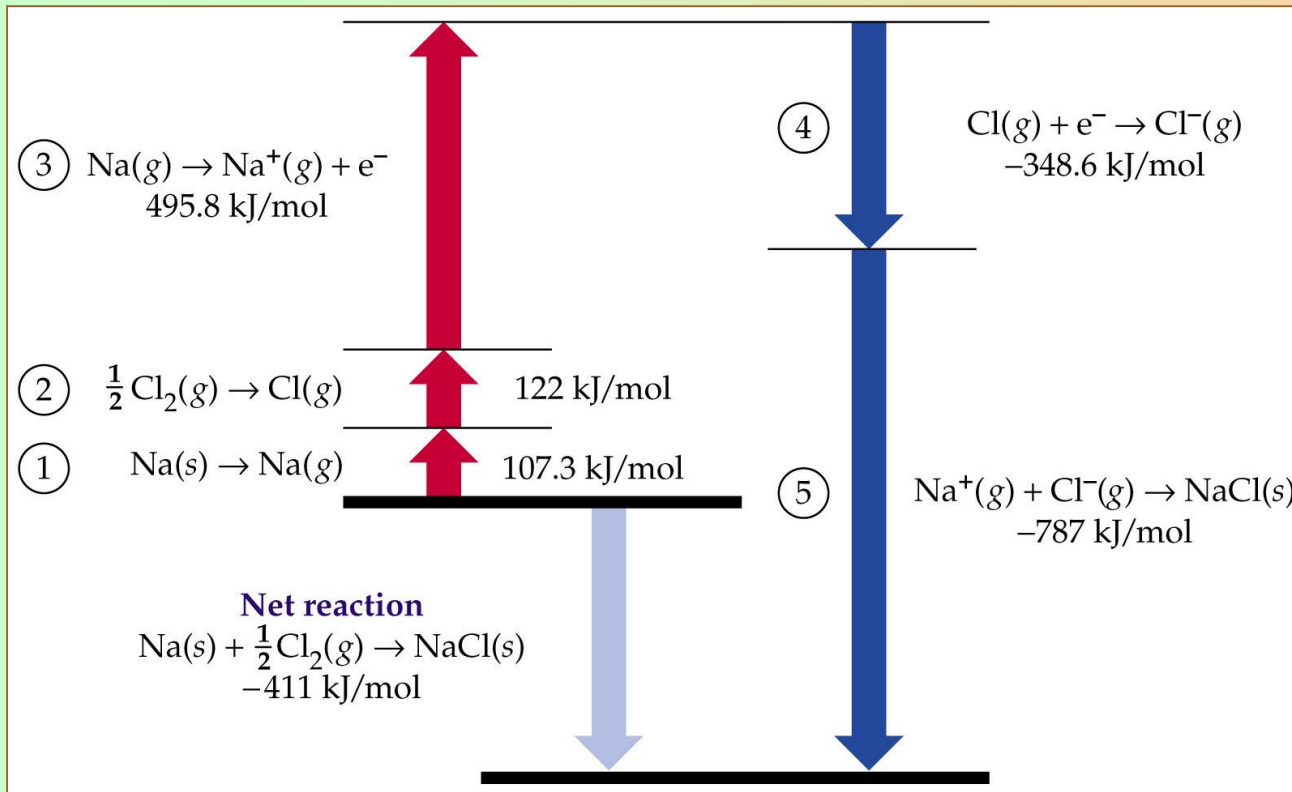

Born-Haber Zikloa

Solido ionikoaen eraketaren urratsak (NaCl)

IOI ISOLATUEN ERAKETA

3. Sodioaren ionizazio-entalpia (IE)
4. Kloroaren afinitate elektronikoa (EA)

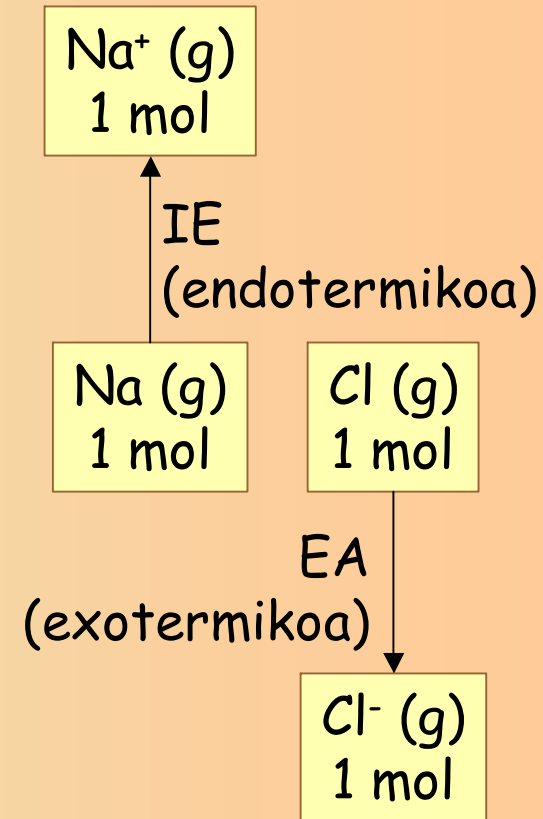
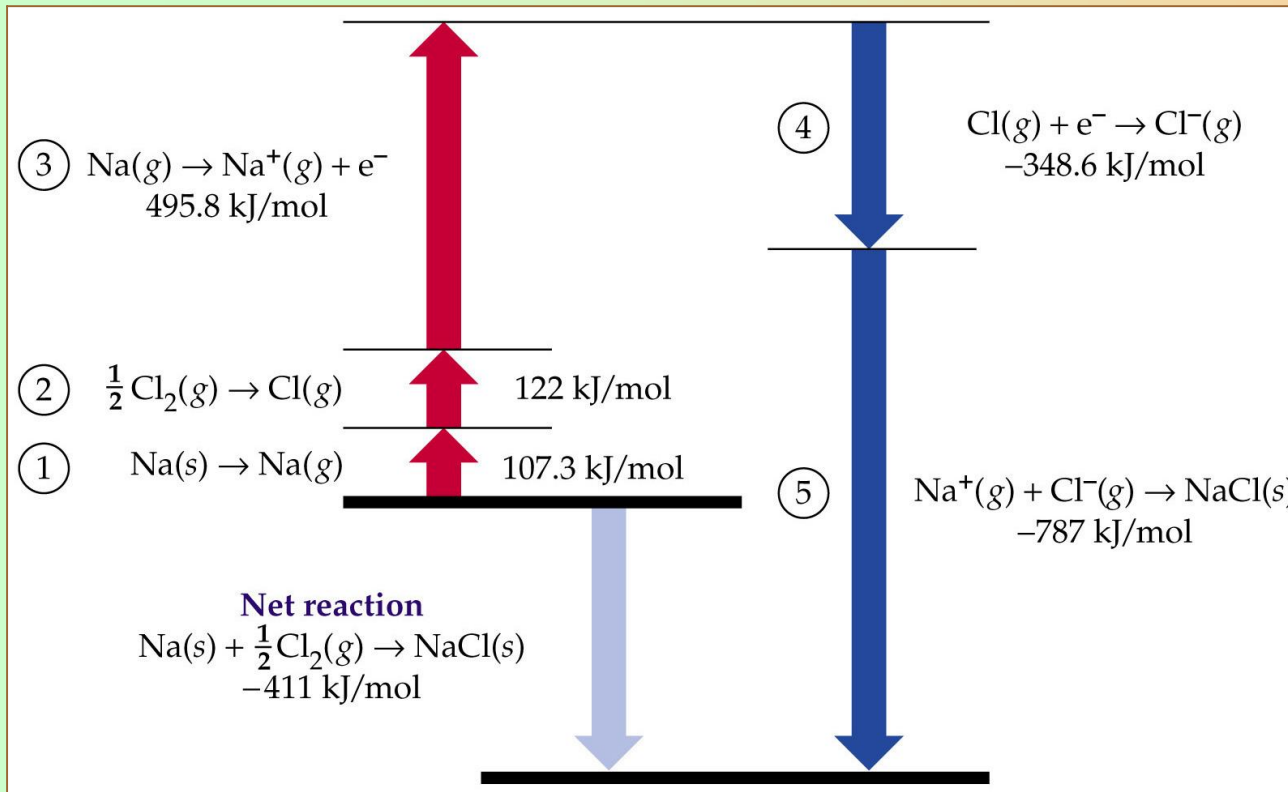

Born-Haber Zikloa

Solido ionikoaen eraketaren urratsak (NaCl)

SOLIDO IONIKOAREN ERAKETA

5. Sare-entalpia (L)

Sodio kloruroaren formazio-entalpia:

$$\Delta H_f^0 = \underbrace{V + \frac{1}{2} D + IE}_{\text{endotermikoa}} + \underbrace{EA + L}_{\text{exotermikoa}}$$

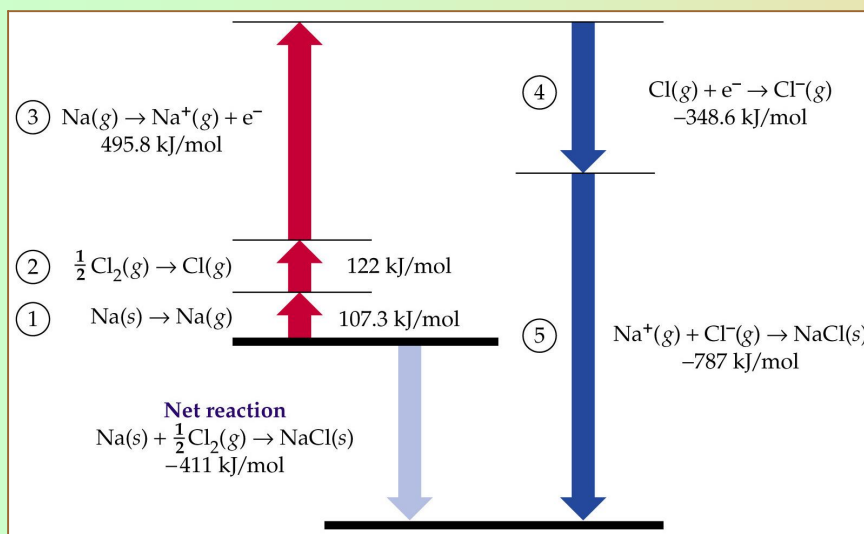
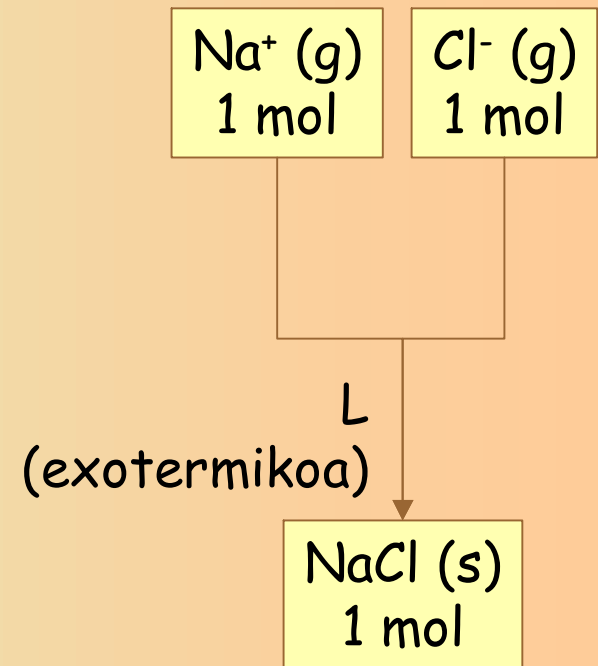

Born-Haber Zikloa

Sare-entalpia

Solido ioniko baten sare-entalpia (energia) konposatu horretan ematen diren lotura ionikoen sendotasunaren neurria da.

