

## Hess-en legea: ariketak

### Ariketa #01

Hona hemen erreakzio hipotetikoak:



- a) Erabili Hess-en legea A→C erreakzioaren entalpia-aldaketa kalkulatzeko  
b) Entalpia-diagrama egin A, B eta C-rentzat eta adierazi nola aplikatzen den Hess-en legea.

a) Entalpia-aldaketa A→C erreakzioarentzat



-----



b) Entalpia-diagrama A, B eta C-rentzat

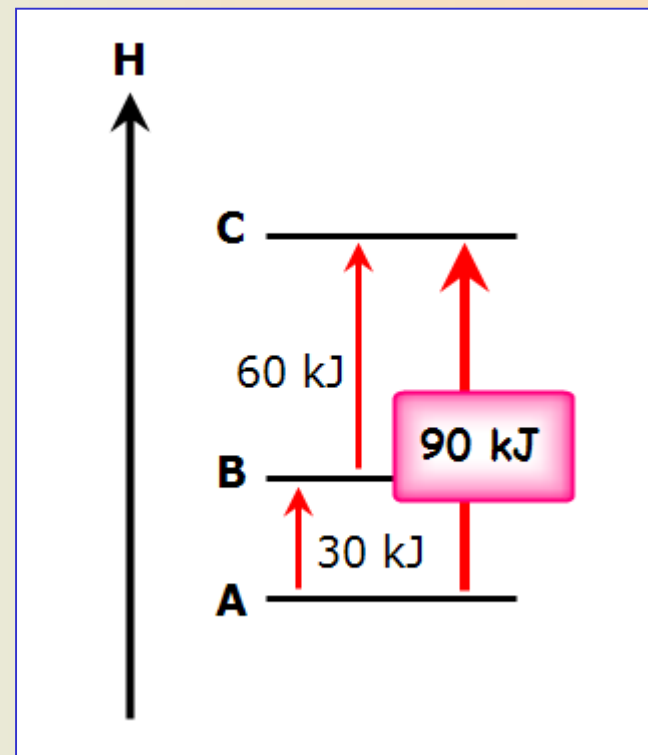

## Hess-en legea: ariketak

### Ariketa #02

Hona hemen erreakzio hipotetikoak :



- a) Erabili Hess-en legea  $Y \rightarrow Z$  erreakzioaren entalpia-aldaketa kalkulatzeko  
 b) Entalpia-diagrama egin X, Y eta Z-arentzat

a) Entalpia-aldaketa  $Y \rightarrow Z$  erreakzioarentzat



-----



b) Entalpia-diagrama X, Y eta Z-arentzat

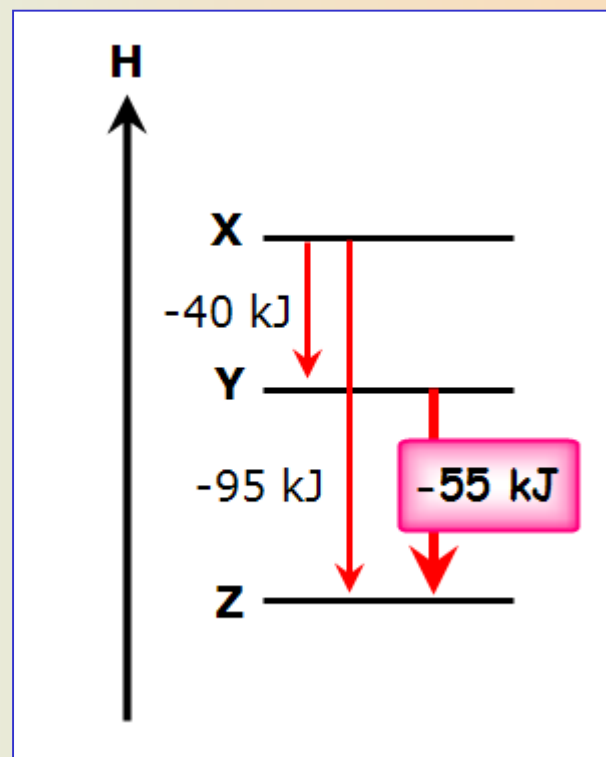

## Hess-en legea: ariketak

### Ariketa #03

Honako entalpia-aldaketa hauek emanik:

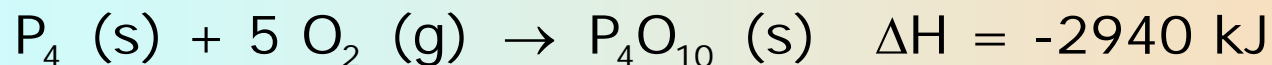
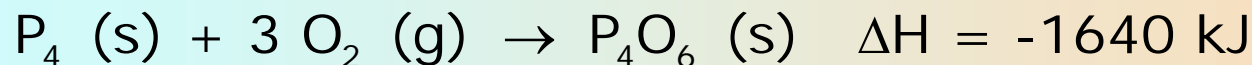

kalkulatu entalpia-aldaketa erreakzio honentzat

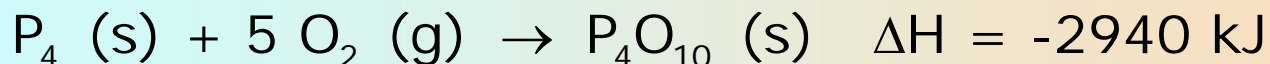
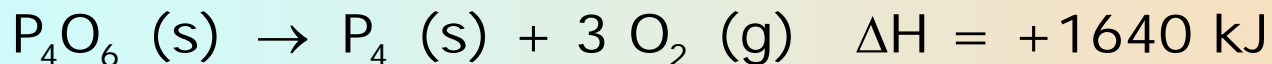
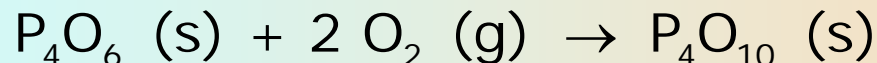

-----

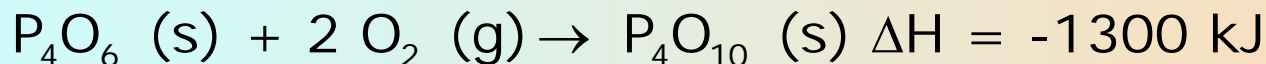

## Hess-en legea: ariketak

### Ariketa #04

Honako entalpia-aldaketa hauek emanik :

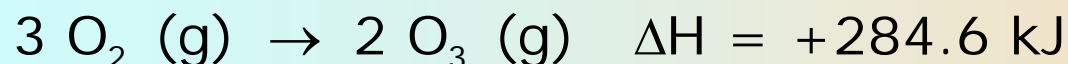
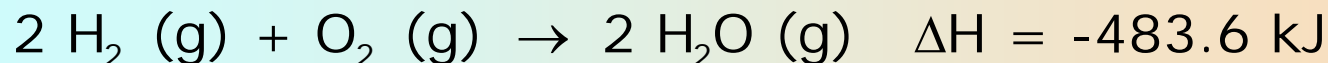

kalkulatu entalpia-aldaketa erreakzio honentzat

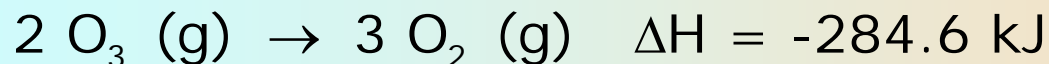
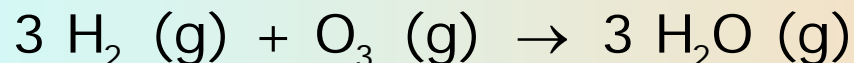

-----

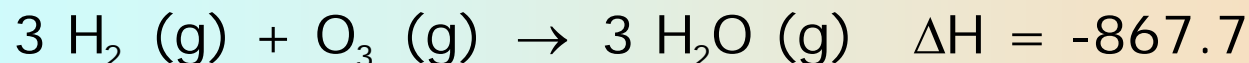
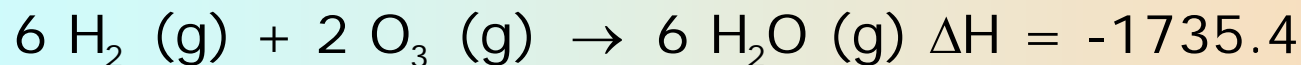

## Hess-en legea: ariketak

### Ariketa #05

Honako entalpia-aldaketa hauek emanik :

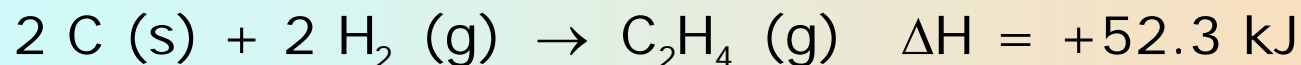
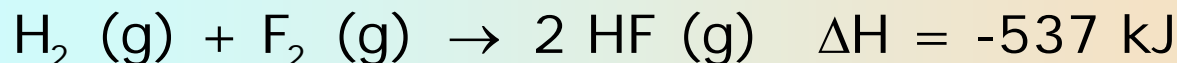

kalkulatu entalpia-aldaketa erreakzio honentzat

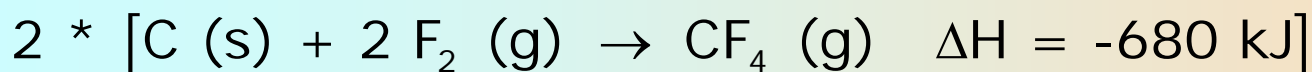
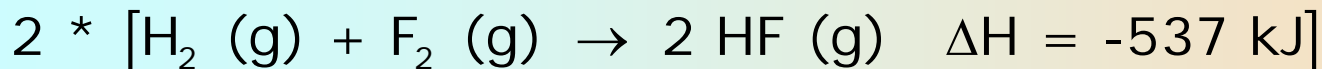
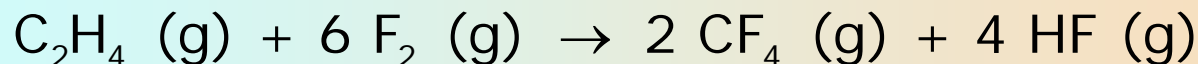

-----

